

MODEL N170S NuVinci™ CVP

The NuVinci Continuously Variable Planetary (CVP) is a revolution in drivetrain technology. A new way of transmitting mechanical power based on spheres instead of gears. It's a new class of highly adaptable and scalable continuously variable transmission (CVT), the first commercially available for the bicycle industry. And a genuine replacement for internally geared hubs and derailleurs that is ideally suited for comfort, cruiser and commuter bicycles.

NuVinci CVP-equipped bicycles offer riders the quietest, smoothest ride ever. They completely eliminate the jerkiness of missed shifts, dropped gears and gear lash. Adjusting the ratio to adapt to the terrain and the individual's fitness and riding style, is as effortless as adjusting the volume on a radio. No noise or hesitations. Riders intimidated by conventional shifting need never suffer a missed gear or dropped chain again.

- The NuVinci CVP is the culmination of a century's worth of continuously variable transmission advances.
- Variable planetary configuration provides the rider a smooth speed ratio change experience in a compact, very durable package. Easiest shifting ever!
- Simple twist controller enables easy, continuous ratio adjustments while pedaling, coasting or at a stop. Easy to read display makes it simple for the rider to find the perfect cadence "sweet-spot".
- The NuVinci CVP advances the state of the art in elastohydrodynamic lubrication and traction CVT technology, and combines it all into a package practical for a bicycle for the first time.
- It benefits from strong automotive "DNA" in CVT technology providing world class reliability, durability and OE quality.
- Represents game-changing breakthrough technical achievements that will attract more riders and grow the bicycle industry, including comfort/cruiser riders, technophiles, performance lifestyle and luxury riders of all ages.



2007 Batavus Adagio-NuVinci
Bike of the Year

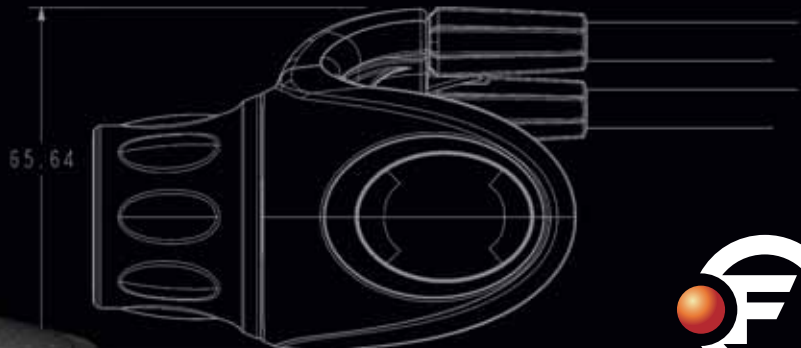

FALLBROOK®
TECHNOLOGIES

Driving the NuVinci™ Revolution

The NuVinci CVP is a CVT that functions like a planetary gear set as well. The NuVinci CVP typically has a central idler, a set of balls distributed about the idler, a rotatable input disc on one side of the idler and the balls and a rotatable output disc positioned on the other side of the idler and the balls. Tilting the axes of the balls varies their respective contact diameters with the input and output discs, varying the transmission ratio.

The result is smooth, seamless and continuous transition to any ratio within its range, maximizing overall powertrain efficiency.

Riders can adjust the ratios continuously as the terrain changes. Whether they are in motion or standing still. This allows for total control unlike any other bike.

For a video demonstration of NuVinci CVP technology, please visit www.nuvinci.com.

Specifications

| | |
|--|--|
| Speed Ratio Steps | Infinitely variable within ratio range |
| Shifting | Variable, twist shifting |
| Brake Options | Rim, Disc, Roller |
| Hub Shell Material | Aluminum |
| Corrosion Resistant Coating | Yes |
| Controller Material | Nylon, 30% Glass Filled |
| Ratio Speed Range | 350% (0.5 Under-Drive To 1.75 Over-Drive) |
| Drop-out Width | 135mm |
| Spoke Hole # | 32, 36 |
| Sprockets Supported* | 16, 17, 18, 19, 20, 21, 22 (standard freewheels) |
| Chain-line | 51mm |
| Average Weight (includes freewheel and mounting hardware) | 4.16 to 4.28 kg. |
| Hub Colors | Satin Black, Satin Silver |
| Controller Color | Satin Black |

* Maximum input torque: 130 Nm; Minimum Allowable "Front Chain ring" / "Rear Sprocket" ratio: 2.0

Controller

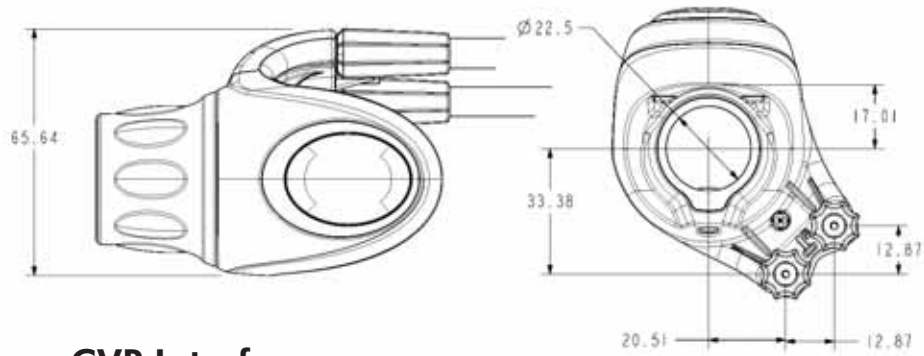

CVP Interface

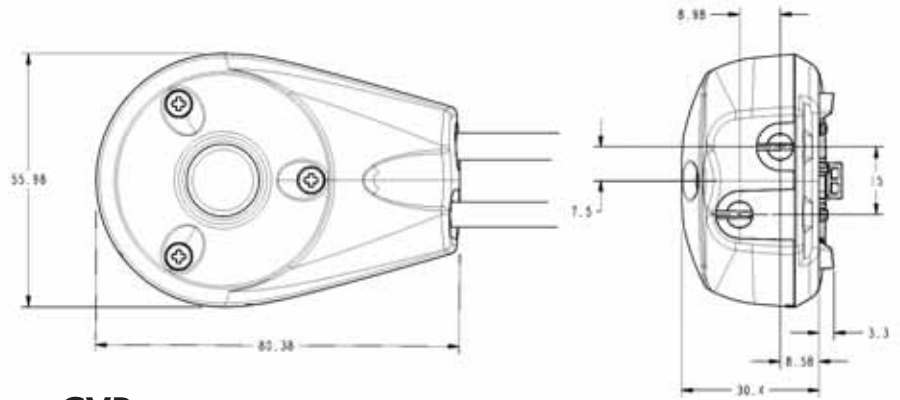

CVP

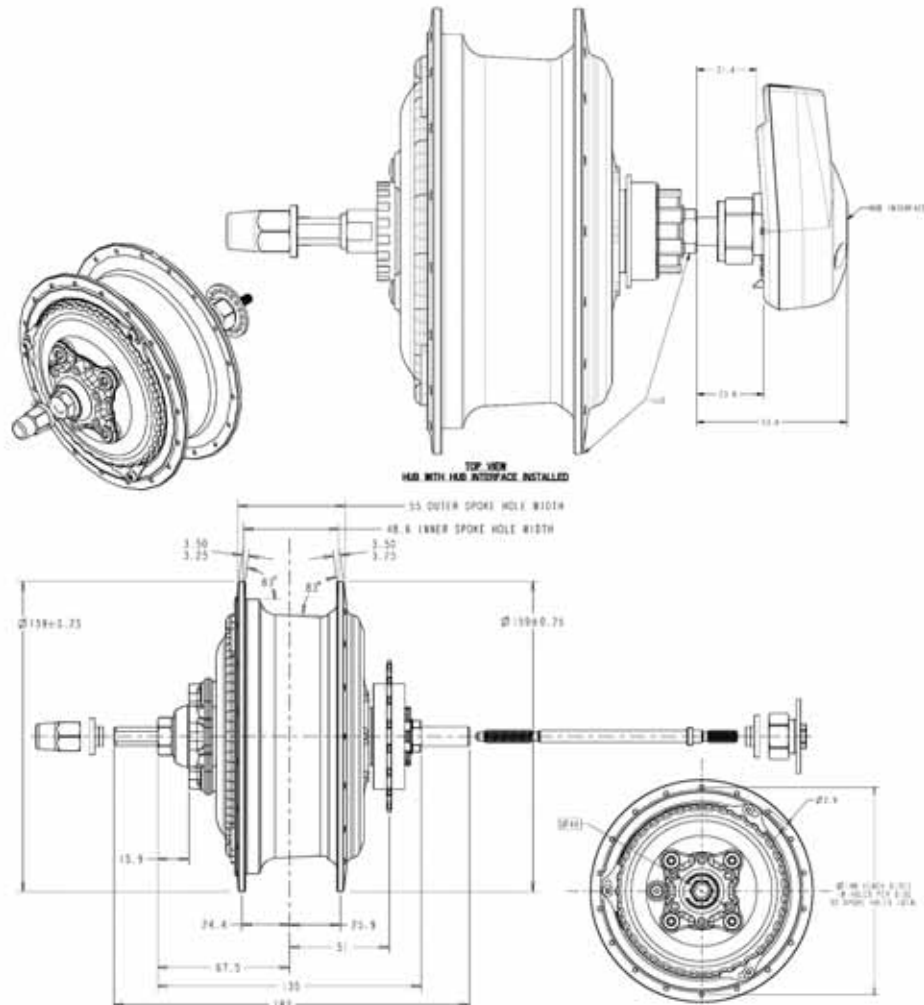

Fallbrook Technologies Inc.
505 Cypress Creek Road
Suite L
Cedar Park, TX 78613

Toll Free: +1 (888) NuVinci (688-4624)
Phone: +1 (512) 279-6200
Fax: +1 (512) 267-0159